

# Grader D-SERIES

836D | 836D AWD | 856D | 856D AWD



**CASE**  
CONSTRUCTION

# STANDARD AND OPTIONS

## STANDARD EQUIPMENT

**NEW** Touchscreen Display is the new central point for all machine information's and settings

**NEW** Side Console on the right side includes ignition key, electrical hand throttle, cup holder and two USB ports to charge your mobile devices. Plus an additional storage compartment below the new side console

**NEW** Keypad that is easy to reach, easy to do settings and easy to clean

**UPDATED** storage compartment on the left side with bottle holder in the back and a net over the compartment to store safely what need to be protect for moving around

**NEW** Joystick controls for comfortable and precise work and drive (on EH models only)

Battery main switch

Cab equipped with two fully swinging doors for both side access, tinted safety glasses, front and rear sunshield

Switchable back-up alarm

Rear view camera

Radio

Rotating beacon

Caliper disc parking brake operating on transmission

NEF STAGE V engine with electronic management and "DualPower"

DOC & SCRoF exhaust gas aftertreatment

Cold start

Control levers for precise and simultaneous moldboard operations

Front and rear fenders

Front wheel spindle steering with adjustable steering column

Air conditioning

High grade steel moldboard with hardened rounded guides

Hydraulic and dual-circuit accumulator brake system operating on tandem wheels

Hydraulically adjustable for 90° bank slope

Hydrostatic front-wheel drive with E.D.C.V. Electronic Drive\*

Control volume and hydraulic differential \*

Internal gearing, sealed, backlash-free and self-adjusting slewing ring operating on 360°

"Load Sensing" hydraulic system with variable displacement pump

Moldboard cutting angle hydraulically adjustable

Oscillating front axle with hydraulic lean adjustment

Oscillating tandem axle with automatic no-spin differential

Powershift transmission with 6 forward and 3 reverse speeds, with integrated torque converter

Rear counterweight

Road traffic lights

Rops/Fops suspended cab, mounted on rear frame

Standard cab

Heated and air suspended seat

Creep mode "AWD" version only

CASE "SiteWatch"

*\*Only on 836D AWD and 856D AWD*

## OPTIONAL EQUIPMENT

Biological hydraulic oil

Floating valve for moldboard

Front lights on cab

Cab roof LED working lights (2 front and 2 rear)

2 Cab bottom LED working lights

Fuel refilling pump (50 l/min)

Left and right moldboard side plates

Low profile cab

Overload clutch on moldboard

Parallel front blade

2 Rear LED working lights

5 teeth rear ripper with protection device

Scarifier on moldboard

Right moldboard extension

Tow coupling

Blade control predisposition (Leica, Trimble)

Front blade with parallel geometry and mechanical depth indicator

Front counterweight for 836D and 836D AWD (510 kg)

Front countweight for 856D and 856D AWD (763 kg)

Tool box

Automatic lubrication system

Note: standard and optional equipment may vary by country. Consult your CASE dealer for specific details.

# SPEC SHEET

## 836D - 836D AWD / 856D - 856D AWD

### BRAKES

Hydraulic, dual-circuit accumulator pump braking with 4 oil bath disc brakes acting on tandem-wheels. Parking brake: disc brake acting on transmission.

### TYRES 836D - 836D AWD

405/70R20 Powerload Goodyear  
 420/75 R20 XMCL TL Michelin  
 455/70 R20 SPT9 Dunlop  
 405/70 R24 SPT9 Dunlop



XMCL MICHELIN      SPT9 DUNLOP      Powerload Goodyear

### TYRES 856D - 856D AWD

17.5 R25 XHA Michelin (transport width<2500 mm)  
 17.5 R25 XTLA G2 Michelin



XHA MICHELIN      XTLA MICHELIN

### TRANSMISSION

Full powershift transmission with 6 forward and 3 reverse gears.  
 Electric single-lever shift with reverse-lock in ranges 3-6.

Speeds in km/h

GEAR	FORWARDS		REVERSE	
	836D 836D AWD	856D 856D AWD	836D 836D AWD	856D 856D AWD
1.	5.4	5.0	5.7	5.4
2.	8.3	7.7	13.3	12.6
3.	12.6	11.8	29.2	27.9
4.	19.2	17.9	-	-
5.	27.9	26.0	-	-
6.	39.9	38.0	-	-

Tractive effort (adherence coefficient 0.8)

836	_____	66 kN
836D AWD	_____	85 kN
856D	_____	95 kN
856D AWD	_____	117 kN

### ALL WHEEL DRIVE

Selectable in addition to the hydrodynamic rear-wheel drive. Hydrostatic front-wheel drive with E.D.C.V. (Electronic Drive Control Volume). A bi-directional swash plate pump (forward/reverse) drives wheel-hub mounted motors in each of the front wheels. Hydraulic No-Spin differential prevents one-sided wheel spin and proportions torque when cornering. A microprocessor monitors and matches front- and rear-wheel drive forces. A stepless switch allows the operator to adapt front-wheel thrust to existing job conditions. Creep mode as standard: front traction only, for ultra low machine speed.

# SPEC SHEET

## 836D - 836D AWD / 856D - 856D AWD

SPECIFICATIONS	836D - 836D AWD	856D - 856D AWD
<b>ENGINE STAGE V "Hi-eSCR2"</b>		
Maximum Power	(ISO 14396/ECE R120)	
From 1 <sup>st</sup> to 3 <sup>rd</sup> gear	kW/hp	102/138   129/173
From 4 <sup>th</sup> to 6 <sup>th</sup> gear	kW/hp	115/156   142/190
Governed	rpm	2100
Make & model	FPT N67 NEF 6 cyl	
Aftertreatment system	DOC+SCRoF	
Donaldson air filter with dust ejector	std	
Type	diesel, common rail, dual power, turbocharged and intercooler	
Displacement	l	6.7
Number of cylinders		6
Bore & stroke	mm	104x132
Maximum torque at 1400 rpm	Nm	725   850
Remote engine oil filter for easy replacement - 25°C outside temperature start as standard equipment. The engine complies with (EU) 2016/1628 regulations STAGE V.		
<b>TORQUE CONVERTER</b>		
Single-stage torque converter integrated into shift gearbox Automatic matching of output torque to changing travel conditions		
Converter ratio		1.87:1   1.91:1
Cooling by heat exchanger		
<b>AXLE FRONT</b>		
Oscillating axle with wheel spindle steering and hydraulic wheel lean adjustment		
Axle oscillation	±	15°
Wheel lean	±	21.45°   20.3°
Ground clearance	mm	485   554
<b>AXLE REAR TANDEM</b>		
CASE tandem grader axle with automatic No-Spin differential		
Oscillating tandem drives with heavy-duty roller chains		
Planetary reduction		
Oscillation	±	15°
Tandem box dimensions		
Height	mm	599   590
Width	mm	201   199
Wall thickness	mm	20
Chain pitch	mm	50.8
Tandem wheelbase	mm	1241   1572.6
<b>STEERING</b>		
Operated from the adjustable steering and control console. Front-wheel spindle steering, all hydraulic, volume control.		
Steering wheel lock. left/right		40°   42.5°
Articulated frame with 2 double-flow steering cylinders: Articulation angle	±	28°
<b>Minimum turning radius:</b>		
across tyres across	mm	6600/6800   7300/7300
front blade	mm	7300/7600   8100/8000
<b>A-FRAME</b>		
Robust welded box section A-frame. L-profile cross section	mm	125x120x8   140x140x10
<b>SLEWING RING</b>		
Internal gearing, sealed roller-mounted, backlash-free, self-adjusting		
Driven by hydraulic motor and moldboard mechanism		
Diameter	mm	1150   1350
Action radius		360°
<b>MOLDBOARD</b>		
Multiradius wear-resistant, high-grade steel with hardened rounded guides. Replaceable, split main and side blades.		
Width	mm	2440/3050/3355   3355/3660/3960
Blade height/thickness	mm	526/15   603/20
Cutting edge height/thickness	mm	152/19
Bolt diameter	mm	16

SPECIFICATIONS		836D - 836D AWD	856D - 856D AWD
<b>MOLDBOARD SETTINGS</b>			
<b>Shifting:</b>			
to the right	mm	491	755
to the left	mm	708	645
<b>Reach across tyres w/o articulated steering:</b>			
right horizontal	mm	1865	2375
left horizontal	mm	1525	1685
<b>Reach across tyres with articulated steering:</b>			
right horizontal	mm	2490	3135
left horizontal	mm	2150	2545
<b>Max. slope angle:</b>			
right horizontal		117°	100°
left horizontal		76°	112°
Max. lift height above ground	mm	394	480
Max. scraping depth	mm	456	500
Cutting angle adjustment, hydr		49.5°	50°
<b>HYDRAULIC SYSTEM</b>			
"Load Sensing" with variable displacement axial piston pump. Zero oil delivery under no-function conditions and hence power savings. Closed system with pressurised tank. Pressure relief valve			
Hydraulic pump		swash plate, variable displacement	
Max delivery	l/min	94.5	126
Max pressure	bar	200	
Pressure relief setting	bar	215	
<b>FRAME</b>			
Front frame: stiff, welded section from high-strength, fine-grain steel			
Cross-section	mm	270x270	300x300
Wall thickness	mm	12	20
Rear frame		torsion resistant frame	
Cross-section	mm	220x260	260x90
<b>CAB</b>			
Elastically mounted, noise insulated ROPS/FOPS cab with two swinging doors. Either side access. Tinted glass.			
Rear-frame mounted cab. Heater/defroster nozzles.			
Heated and Air Suspended seat.			
Low profile Cab option reducing overall grader height by 180 mm.			
ROPS according to EEC sample testing		ISO 3471	
FOPS according to EEC sample testing		ISO 3449	
Cab noise level	dba	75	
External noise level	dba	99	
<b>ELECTRICAL SYSTEM</b>			
Voltage	V	24	
Batteries	Ah	2x100	
Alternator	A	90	
Starter	kW	4	
<b>CAPACITIES</b>			
Lube oil	l	12.5	
Coolant (Including: cooler and Heater	l	32	
Transmission (including converter and cooling)	l	27	
Axle gear	l	31	36
Tandem	l	120	128
Worm gear	l	2	2.5
Hydraulic tank	l	70	90
Hydraulic oil, total	l	170/185	185/200
Fuel tank	l	278	
AdBlue tank	l	54	

# DIMENSIONS AND SPECIFICATIONS

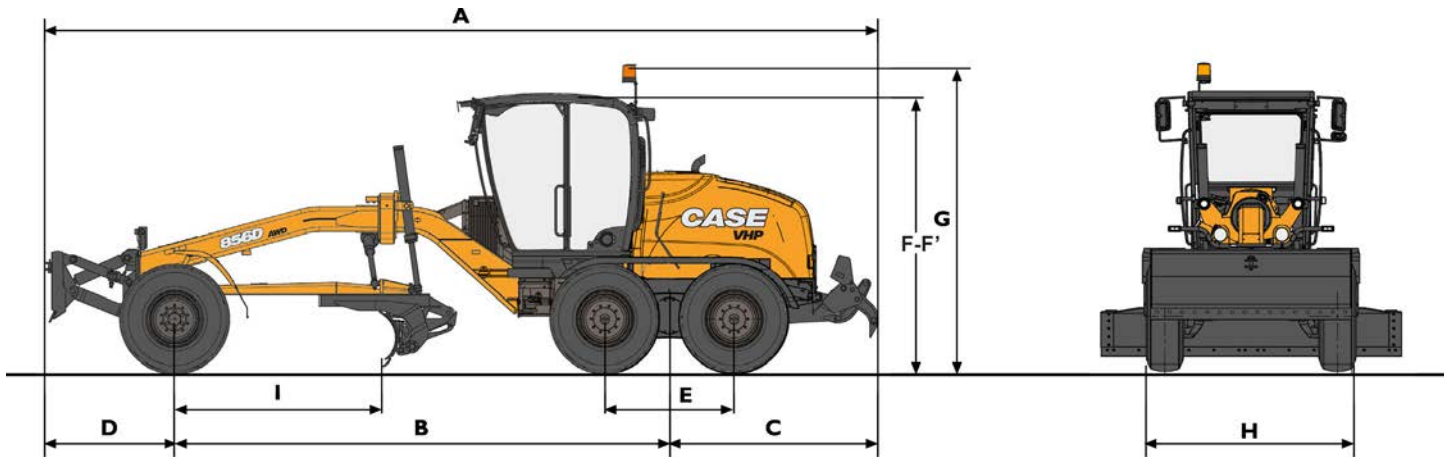

836D, 836D AWD EQUIPPED WITH:		FRONT & REAR COUNTERWEIGHT	FRONT BLADE & REAR COUNTERWEIGHT	FRONT COUNTERWEIGHT & REAR RIPPER	FRONT BLADE & REAR RIPPER
A Total length	mm	7697	8372	8331	8961
B Wheelbase	mm	5351	5351	5351	5351
C Rear attachment end	mm	1605	1605	1605	1605
D Front attachment end	mm	762	1436	762	1436
E Tandem base	mm	1241	1241	1241	1241
F Standard cab height	mm	3240	3240	3240	3240
F' Low profile cab height	mm	3060	3060	3060	3060
G Max machine height	mm	3586	3586	3586	3586
H Width over tyres	mm	2303	2303	2360	2360
I Blade base	mm	1997	1997	1997	1997

Dimensions referred to a machine equipped with 405/70R20 tires. Machine height and width over tires may vary with other tires.

856D, 856D AWD EQUIPPED WITH:		FRONT & REAR COUNTERWEIGHT	FRONT BLADE & REAR COUNTERWEIGHT	FRONT COUNTERWEIGHT & REAR RIPPER	FRONT BLADE & REAR RIPPER
A Total length	mm	8592	9317	9285	10044
B Wheelbase	mm	6023	6023	6023	6023
C Rear attachment end	mm	1785	1785	2458	2458
D Front attachment end	mm	809	1568	809	1568
E Tandem base	mm	1572	1572	1572	1572
F Standard cab height	mm	3330	3330	3330	3330
F' Low profile cab height	mm	3150	3150	3150	3150
G Max machine height	mm	3674	3674	3674	3674
H Width over tyres	mm	2549	2549	2555	2555
I Blade base	mm	2504	2504	2504	2504

Dimensions referred to a machine equipped with 17.5R25EM tires. Machine height and width over tires may vary with other tires.

<b>MACHINE WITH:</b>		<b>836D</b>	<b>836D AWD</b>	<b>856D</b>	<b>856D AWD</b>
Front & rear counterweight	kg	11701	12001	14976	15376
Front blade & rear c/w	kg	11805	12105	15140	15540
Front c/w & rear ripper	kg	12005	12305	15407	15807
Front blade & rear ripper	kg	12109	12409	15571	15971
Max. operating weight	kg	12500	12800	16250	16650

With low Profile Cab the weight is reduced by: 35 kg

		<b>836D - 836D AWD</b>	<b>856D - 856D AWD</b>
<b>HYDRAULICALLY CONTROLLED FRONT BLADE</b>			
Blade width	mm	2350	2450
Blade height	mm	765	870
Penetration depth	mm	136	174
Max. ground clearance	mm	509	547
<b>HYDRAULICALLY CONTROLLED REAR RIPPER FOR HEAVY DUTY APPLICATIONS</b>			
Ripping width	mm	2049	2268
Ripping depth	mm	310	371
Number of shanks	n°	5	5
Interval of shanks	mm	500	555
<b>THE MOVABLE MOLDBOARD SCARIFIER CAN BE OPERATED IN BOTH DIRECTIONS</b>			
Number of shanks	n°	4	6
Scarifying width	mm	900	1080
<b>RIPPING TRACK DISPLACEMENT</b>			
Left	mm	420	580
Right	mm	950	1200
Scarifying depth	mm	134	202