

**G-SERIES WHEEL LOADERS**  
**521G | 621G**  
**STAGE IV**

**CASE**  
CONSTRUCTION



**MOVING**  
**MOUNTAINS**

[www.casece.com](http://www.casece.com)  
**EXPERTS FOR THE REAL WORLD**  
**SINCE 1842**

# G-SERIES WHEEL LOADERS



## EXPERTS FOR THE REAL WORLD SINCE 1842

- 1842** CASE is founded.
- 1869** The first CASE portable steam engine - road construction is born!
- 1958** The first CASE 4-WD wheel loader, the W9, is introduced.
- 1969** CASE begins skid steer loader production.
- 1998** Ride control on loader backhoes and skid steer loaders: another CASE first. From 1998 CASE Wheel Loaders run FPT engines, leaders in industrial engine technology.
- 2001** The exclusive mid-mounted Cooling Cube in CASE wheel loaders means clean engine, reliability and massive bucket payloads.

# HERITAGE

## A TRADITION OF INDUSTRY FIRSTS



- 2011** *CASE is the first in the industry to launch a 5-speed lock up transmission*
- 2012** *CASE completes its EU Stage IIIB wheel loader range: a further step forward in emissions reduction and once again the first in the industry.*
- 2015** *CASE wheel loaders achieve EU Stage IV emissions standards while further increasing fuel efficiency without a DPF.*
- 2017** *New G series wheel loaders are launched.*
- 2019** *CASE begins introducing Stage V models in Europe, still without traditional DPF. CASE shows, for the first time ever in the industry, the concept of a Compressed Natural Gas (CNG) wheel loader: ProjectTETRA.*

# G-SERIES WHEEL LOADERS



## HIGH EFFICIENCY with no EGR or particulate filter

The engine was developed and manufactured by our award winning sister company FPT Industrial, which produces over 500,000 engines per year and powers world record winners.

The in-house design leverages advanced technologies developed for commercial vehicles and agriculture, and introduces specific tailored solutions for off-road applications.

The NEF N67\*, with 6 in-line cylinders and a 6.7 litre displacement, is designed to offer both fuel efficiency and reliability with plenty of power available.

- The air intake flow is increased by a turbocharger with air-to-air cooling.
- The multiple injection delivers best-in-class high torque performance at low rpms.
- No EGR valve is used: 100% fresh air is taken for combustion without DPF and no extra cooling system is needed.

Our engine technology is so reliable that it is trusted by the French Sea Rescue service for their boats: what better guarantee could you wish for?



\* 521G is fitted with N45 engine

# ENGINE KEEP IT SIMPLE



## LOW EMISSIONS without particulate filter

With HI-eSCR after-treatment, FPT technology meets EU Stage IV emissions standards, a big step towards cleaner air. With this system, fewer components are involved, engine oil quality is not compromised and there is no need for a particulate filter (DPF) or

additional cooling. This allows for a very compact engine compartment, resulting in excellent rear visibility. In addition, the maximum temperature reached by HI-eSCR is 500°C, 200°C below the maximum temperature of a particulate filter.



**HI-eSCR**



1996: EU Stage I

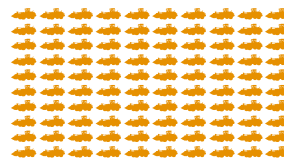

2011: EU Stage IIIB

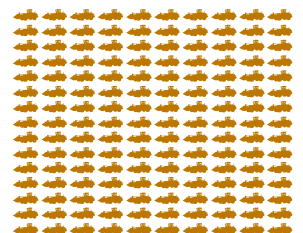

2015: EU Stage IV

It would take six months for a Stage IV wheel loader with Hi-eSCR technology to produce the particulate and NOx emissions that a Stage I wheel loader would produce in one day.

In addition to traditional diesel, the Stage IV NEF engines are capable of running also on B7 biodiesel.

# G-SERIES

## WHEEL LOADERS

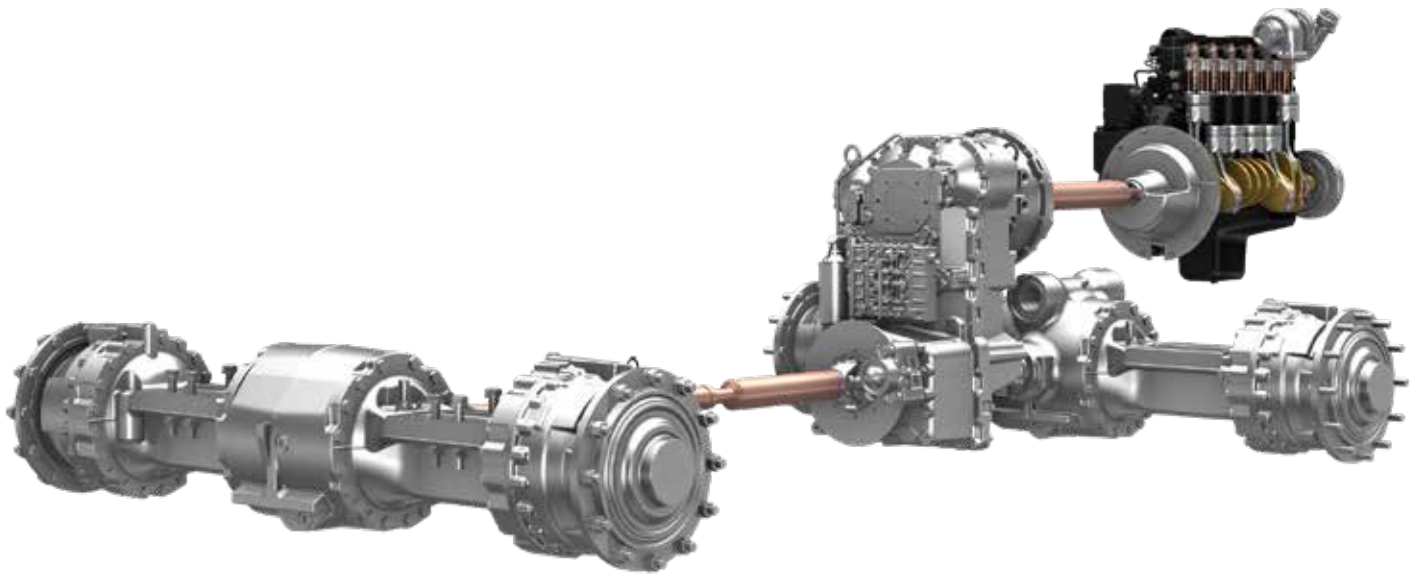

### HIGH RELIABILITY

#### Heavy-duty axles

The heavy-duty axles are tougher, bigger and easier to service thanks to the 3-piece housing design. Wet multiple disc brakes, made of resistant sintered bronze, are located in each wheel hub. Our heavy-duty axles are engineered to support L5 or solid tyres for very abrasive environments. Solid tyres can be factory fitted.

A higher value results from:

- 20-30% lower tyre wear because of no slippage between the wheels.
- reduced fuel consumption because there is no friction in the differential.
- reduced downtime for maintenance because of fewer moving components with open differentials.



### COST SAVINGS

#### 100% auto-lock differential

With open differentials, no friction is applied to reduce wheel slip. As a result, there is less tyre wear and lower energy losses.



With the 100% auto-lock, 100% of the available torque is transmitted to the wheels to provide maximum tractive effort.



# AXLES AND DIFFERENTIALS

## WHEN EFFICIENCY MEETS PRODUCTIVITY

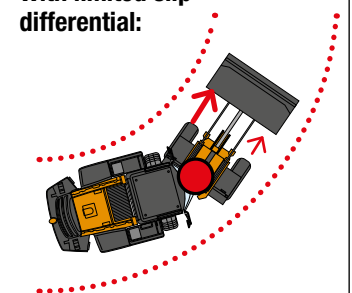
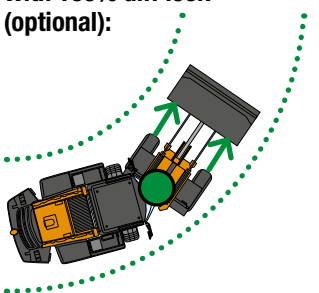

Loading on soft ground		Taking a curve on solid ground	
<p><b>With limited slip differential:</b></p>  <ul style="list-style-type: none"> <li>- 70% tractive effort transmitted to the wheels</li> <li>- Automatic engagement</li> </ul>	<p><b>With 100% diff lock (optional):</b></p>  <ul style="list-style-type: none"> <li>- 100% tractive effort transmitted to the wheels</li> <li>- Automatic or manual engagement</li> </ul>	<p><b>With limited slip differential:</b></p>  <ul style="list-style-type: none"> <li>Automatic slip limited engagement</li> <li>- Internal losses and wind up</li> <li>- Increased tyre wear</li> </ul>	<p><b>With 100% diff lock (optional):</b></p>  <ul style="list-style-type: none"> <li>No engagement (open diff)</li> <li>- No energy loss</li> <li>- Less tyre wear</li> </ul>

# G-SERIES WHEEL LOADERS

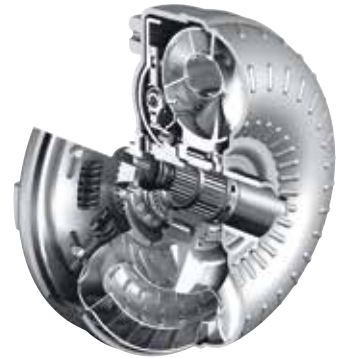

## HIGH EFFICIENCY

### ProShift transmission

ProShift transmission provides on average 1.5 litre/hour fuel saving and up to 20% faster cycle time.

This is the result of three premium features:

1. 5-speed transmission

The 5 speeds allow to always work at lower rev's compared to 4-speed transmission. Lower rev's result in lower fuel usage. When the ECO mode is selected not only the engine gives priority to fuel efficiency but also the transmission shifts at lower rev's in order to increase fuel efficiency and noise emission.

2. Torque converter lock-up

Wheel loaders continuously shift gears and every time diesel saving is achieved with:

- Torque converter lock-up that kills viscous losses from 2<sup>nd</sup> up to 5<sup>th</sup> gear
- Engine de-rating during gear shifts that kills torque peaks in the clutch and contributes to lower fuel usage

# PROSHIFT TRANSMISSION GO FASTER, STAY EFFICIENT



## EASY TO USE

### Intelligent Clutch Cut off with Power Inch

#### 3. Power Inch

With Power Inch, positioning the loader is as smooth as with a hydrostatic transmission, with the added advantage of massive pushing power delivered by the torque converter. This also prevents rolling back on slopes.

The automatic start of the transmission in 2<sup>nd</sup> gear reduces operator fatigue, fuel usage and stress on the torque converter. With the further enhancement of a torque-based 2- to-1 downshift, the transmission will downshift automatically based on machine load or manually with the kick-down button located on the joystick.

# G-SERIES WHEEL LOADERS



## HIGH RELIABILITY

### CASE cooling cube

The unique design of the CASE cooling cube, with five radiators mounted to form a cube instead of overlapping, ensures a constant flow of fresh and clean air from the sides and from the top, to maintain constant fluid temperatures.

The cube structure provides easy access to radiators for a more effective cleaning and serviceability: additional cleaning can also be easily done manually, with separate access to each radiator.

### Designed for dusty environment

The cooling system is mounted behind the cab, far from the rear bumper of the machine and from the ground: away from the dust.

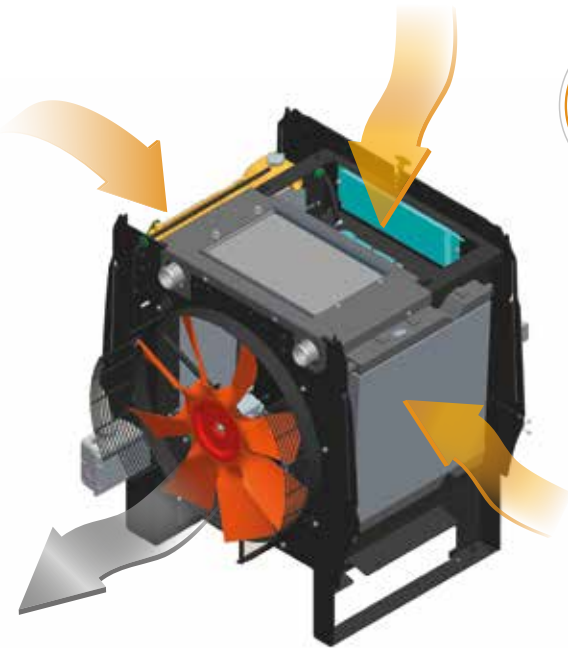

# CASE COOLING CUBE THE ANTI-CLOGGING SOLUTION



## SUPERIOR COOLING EFFECTIVENESS

### Heavy-duty cooling

Handling fertilizer, cereals, animal feed or other materials indoors usually leads to radiator clogging. CASE's solution is the heavy-duty cooling option, available on 621G models, which features:

- Sealed radiator covers that ensure the cooling air is 100% filtered.
- Wide core radiators increase self cleaning with the reversible fan and prevent clogging.



### HEAVY-DUTY COOLERS INSIDE

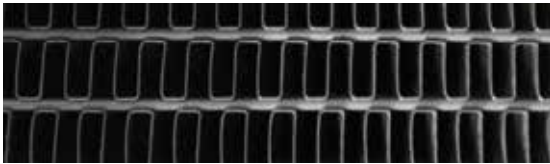

Heavy-duty



Standard

# G-SERIES WHEEL LOADERS



# NEW CAB

## THE ULTIMATE COMFORT



### HIGH VISIBILITY

#### Front visibility

- The one-piece design windshield provides an unobstructed panoramic view.

#### Rear Visibility

- Multiple rear view convex mirrors, a rear view display, the slim engine hood and rear grid defroster ensure optimum rear visibility.

#### Night Visibility

- LED lighting is so effective that you won't see any difference between night and day work.



### OPERATOR PROTECTION

#### Noise and vibration

- The new active suspension premium seat features electronic auto-weight adjustment, a dynamic dampening system and a low frequency shock absorption system. Combined with the suspended cab mount and the positioning of the engine at the rear, this reduces the noise and vibrations the operator is subjected to.
- Noise in the cab is not only low (68-69 dB): it also sounds great.

#### Cab air

- Primary and recirculation filtration efficiency now reaches 99% of particles with improved dust capacity and longer replacement intervals. When working in particularly tough conditions, additional active carbon filters can be fitted.

#### Cab access

- Access is easier and safer thanks to the optimised handrails and the pull-type handle.



### OPERATING COMFORT

#### Seat and controls

- The seat mounted armrest gives more accurate control and comfort. It features 3<sup>rd</sup>/4<sup>th</sup> function proportional control integrated in the joystick, as well as the option of replacing the joystick with two or three (for the 3<sup>rd</sup> function) fingertip levers.
- New joystick steering: the operator handles two equally sized joysticks, just like on an excavator, which reduces fatigue. It features speed proportional sensitivity and slow/medium/fast settings.
- The suspended seat includes seat heaters which warm it up in the cold winter mornings.

#### User interface

- The premium control interface with 8" color display offers intuitive navigation through the machine's information and settings.
- The hands free calling kit features an integrated microphone connected to the radio via Bluetooth.

#### Life on board

- The CASE electrically powered cool box keeps your lunch fresh all day long.
- Multiple storage areas enable you to store documents, beverages and personal objects conveniently.

# MAINTENANCE AND ADDITIONAL OPTIONS

## EASINESS AND PROTECTION



The layout of the components under the hood is optimised and results in easier maintenance



Hood opening and battery on/off switches. In case of flat battery, hood can be opened externally with Remote jump start



Grouped drains for clean and quick oil changes



## SAFE AND EASY MAINTENANCE

### Ground level serviceability

- One-piece electric hood\*

The positioning of the engine at the rear and the easy-to-open electric hood provide fast access to the service points. Jumper cables are available as standard for jump starting the engine if the battery is low.

- Grouped service points

Don't be surprised if you don't see any safety handrails around the hood or steps behind the rear wheels, all service points are easily accessible at ground level. You can do a fast visual check of the hydraulic and transmission oil levels. The three drains are grouped together on the left side, so that fluids are easy and quick to replace.

- Greater safety

All the main service points are easily accessible from the ground, so you can carry out your daily maintenance safely and efficiently.

\* On 521G hood opening is mechanical

# G-SERIES WHEEL LOADERS

## Waste Handler guards for 621G



Bottom guards (front and rear)



# TELEMATICS ANTICIPATION AND CONTROL

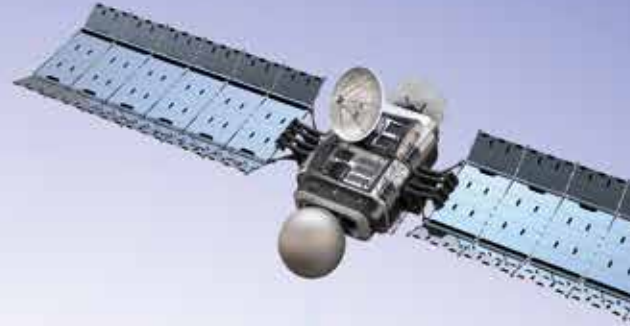

**CASE**<sup>®</sup>  
CONSTRUCTION

**SiteWatch**<sup>™</sup>

## THE SCIENCE BIT

The Case SiteWatch telematics system uses a high-tech control unit mounted on each machine to collate information from that machine and from GPS satellites. This data is then sent wirelessly through the mobile communication networks to the Case Telematics Web Portal.

### SiteWatch: centralised fleet control benefits at your fingertips

#### 📶 Measure your true asset availability and optimise it

- Eliminate the “phantom fleet”: SiteWatch allows to identify spare units or under loaded machines on each site.
- Able to reallocate units where they are more needed.
- Maintenance planning is easier since the actual machine hours are available and alerts will be sent when a service is due.
- Extend the benefits of SiteWatch to the rest of your fleet: SiteWatch can be installed on the units of other brands as well.

#### 📶 Challenge your Total Cost of Ownership!

- Being able to compare the fuel usage of different machine types will allow you choose the right equipment.
- Save on transport costs with planned and grouped service intervention.
- Peace of mind, optimised uptime and lower repair costs:  
with preventive maintenance you can be alerted if the engine needs to be serviced and avoid a disruptive breakdown.
- Be able to compare your asset Return On Investment on different sites.
- Your equipment is used only during working hours. You can receive alerts when is in use during the weekend or at night.

#### 📶 More Safety, Lower Insurance Premium

- Keep thieves away: dissuade them from attacking your asset because it is geo-localised. SiteWatch is hidden so that thieves can't find it quickly.
- Geo-fence your assets. You can define a virtual fence and receive an email when a machine exits that perimeter.
- Recover your asset if it is taken away, thanks to the continuous asset's tracking.



# MAIN REASONS TO CHOOSE THE G-SERIES



## OPERATOR PROTECTION

- Viscous cab suspension
- Pressurized cab with high efficiency filtration
- Low noise (68-69 dB) and vibration



## BEST-IN-CLASS VISIBILITY

- One-piece design windshield, high-efficiency lighting, convex rear mirrors and rear view camera provide optimum visibility 24 hours a day



## HIGH PRODUCTIVITY

- Up to 38% payload-to-weight ratio
- Best-in-class breakout force



## HIGH EFFICIENCY

- Optimized combustion efficiency with Hi-eSCR
- Optimized power transmission with 5-speed transmission and lock-up clutch





## **SUPERIOR COMFORT**

- Seat mounted console
- Premium control interface with 8" display
- Hands-free calling kit
- Multiple storage areas
- Active suspension premium seat



## **SAFE AND EASY MAINTENANCE**

- The rear mounted engine below the electric easy-to open hood is accessible at ground level. Grouped drains rationalise maintenance operations.



## **HIGH RELIABILITY**

- Heavy-duty axles
- 100% differential lock
- Best-in-class cooling system with cube layout